

IT

Struttura a monoscocca in acciaio inox AISI 304; finitura esterna satinata scotch-brite; spessore di isolamento pari a 85mm per la scocca e 65mm per la porta, con schiumatura ad alta densità (40 kg/m3) senza HFC; piedini in acciaio inox regolabili h120/150mm; cella con angoli interni arrotondati per una perfetta pulizia ed igienicità; sbrinamento ed evaporazione dell'acqua di condensa a gas caldo; griglie GN 2/1 in rilsan; cremagliere porta griglie in ABS amovibili, senza l'ausilio di utensili; flusso d'aria laterale; porte auto-chiudenti da 100°; unità refrigerante a monoblocco brevettata e tropicalizzata (in classe climatica 5); serratura di serie; alimentazione a 230V/50Hz monofase standard.

EN

Stainless steel AISI 304 monocoque structure; scotch-brite external satin finish; 85 mm high density HFC free polyurethane foam insulation (40kg/m3) for the body and 65mm thickness for the door; stainless steel adjustable feet h120/150; cell with rounded internal edges for a perfect cleaning and hygiene; hot gas defrosting and condensation water evaporation; GN 2/1 rilsan grids; removable racks for ABS grids, no tools needed; lateral air flow; self-closing doors from 100°; patented and tropicalized monobloc refrigerating unit (climatic class 5); lock as standard; standard power supply 230V/50Hz monophase.

FR

Structure à caisse unique en acier inox AISI 304; finition extérieure satinée Scotch-brite; épaisseur d'isolation par injection de mousse polyuréthane à haute densité (40 kg/m3) sans HFC de 85mm pour la caisse et de 65 mm pour la porte; pieds réglables h120/150mm; chambre froide avec angles internes arrondis pour un nettoyage et une hygiène parfaits; dégivrage et évaporation de l'eau de condensation par gaz chaud; grilles GN 2/1 en Rilsan; crémaillères amovibles sans outils pour grilles en ABS; flux d'air latéral; porte à fermeture automatique de 100°; unité frigorifique avec monobloc breveté et tropicalisé (classe climatique 5); serrure de série; alimentation standard 230V/50Hz une seule phase.

DE

Monocoque-Ausführung aus Edelstahl AISI 304 mit satinierten Außenflächen (Schoch-Brite); 85 mm starke Rahmen-Isolierung und 65 mm starke Tür-Isolierung aus hochverdichtetem Polyethanschaum (40kg/m3) ohne HFC; Stellfüße aus Edelstahl H 120/150; Kühlzelle mit abgerundeten Innenecken für eine einfache Reinigung und optimale Hygiene; automatische Kondenswasserverdunstung und Abtauung durch heißen Gas; Rilsan Gitter GN 2/1; ABS-Stangen für Gitter, abnehmbar ohne den Einsatz von Werkzeugen; seitliche Belüftung; selbstschließende Tür ab 100°; patentiertes und tropikalisiertes Monoblockkälteaggregat (Klimatische Klasse 5); serienmäßiges Schloss; Standard Spannung 230V/50Hz einphasig.

ES

Estructura monocasco de acero inoxidable AISI 304; acabado exterior satinado scotch-brite; espesor de aislamiento 85 mm para el casco y 65 mm para la puerta con espuma de poliuretano de alta densidad (40 kg/m3) sin HFC; piés ajustable de acero inoxidable h120/150mm; cámara con equinas interiores redondeadas para un perfecta limpieza y higiene; deshielo y evaporación del agua de condensación "a gas caliente"; rejillas GN 2/1 de rilsan; cremallera para rejillas de ABS extraíbles, sin el uso de herramientas; flujo de aria lateral; puertas con autocerrado con bloqueo a 100°; unidad refrigeradora monocasco patentada y tropicalizada (en clase climática 5); cerradura de serie; alimentación de 230V/50Hz monofásica estándar.



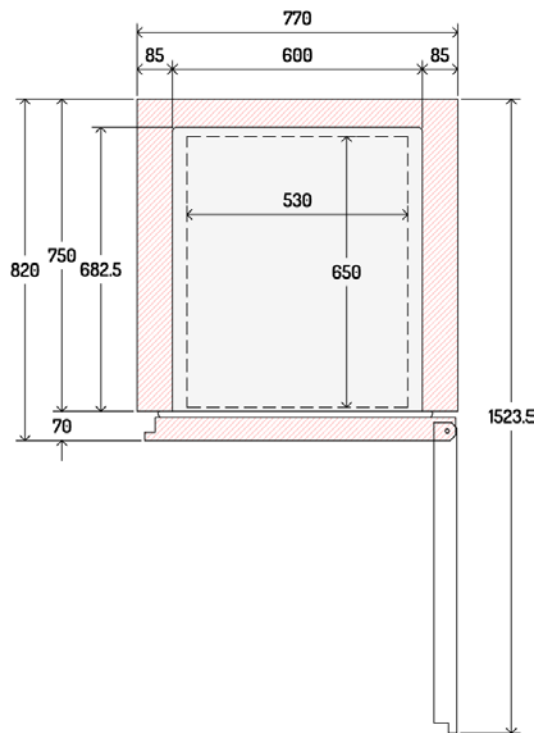
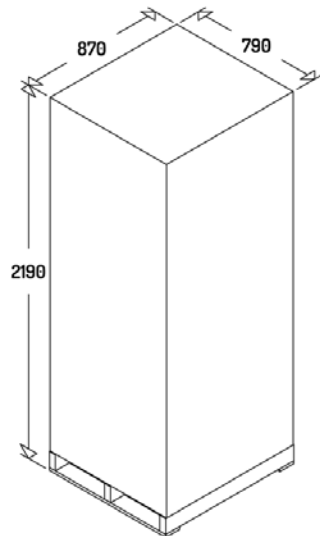
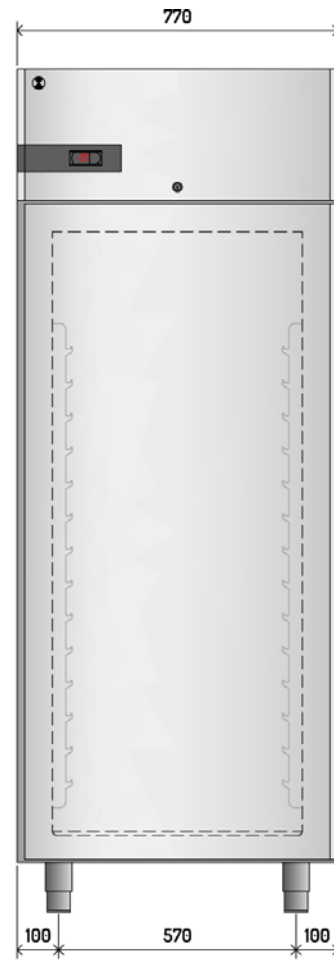
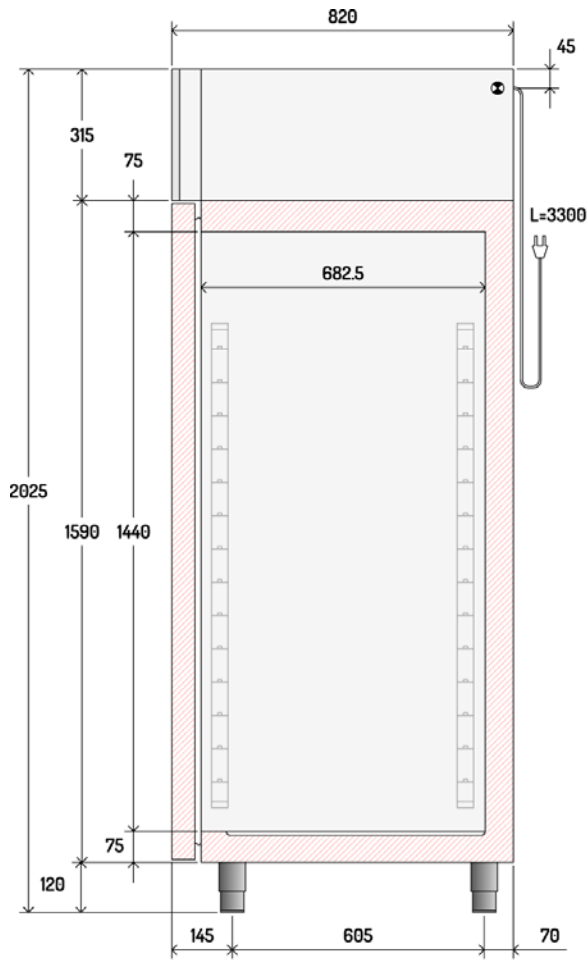

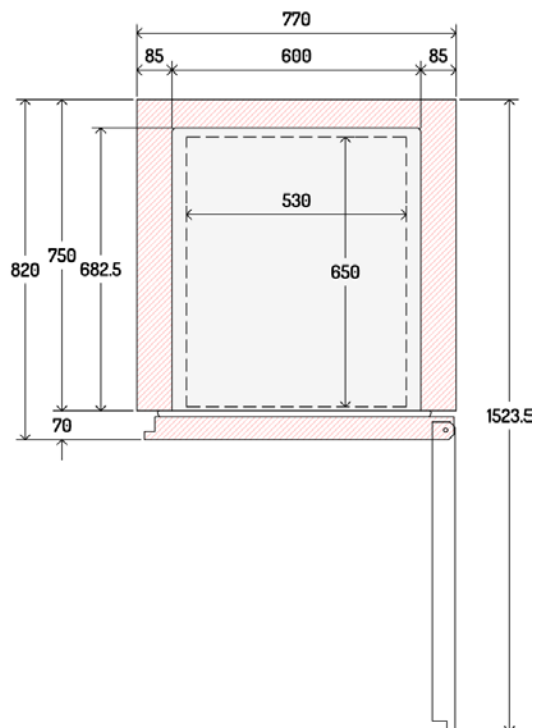
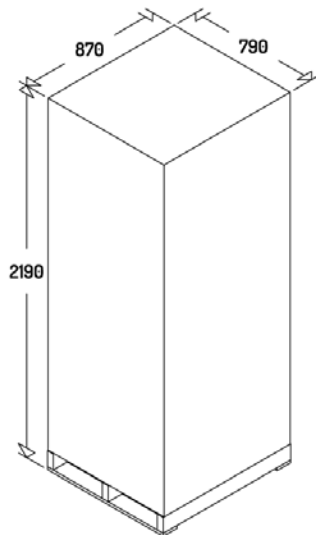
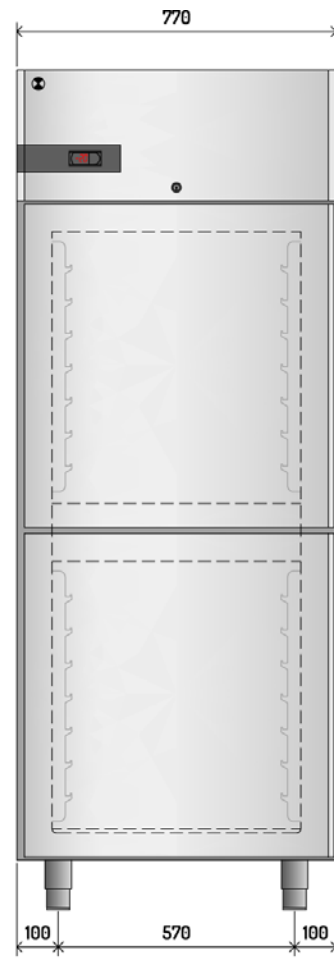
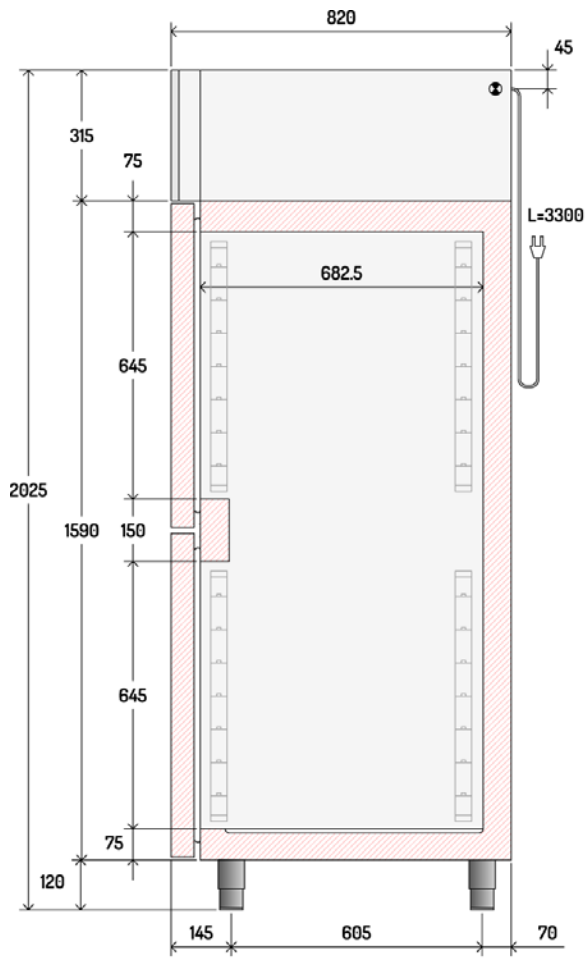

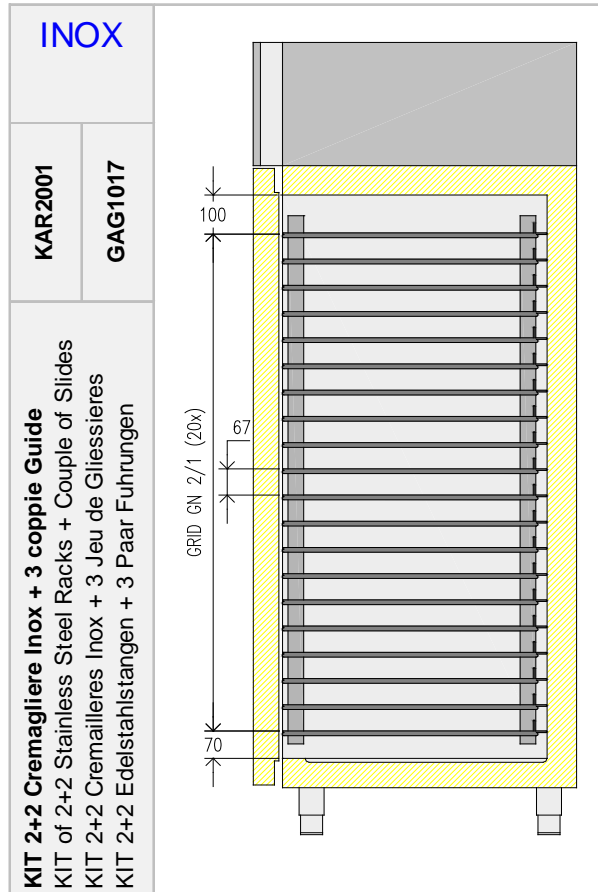
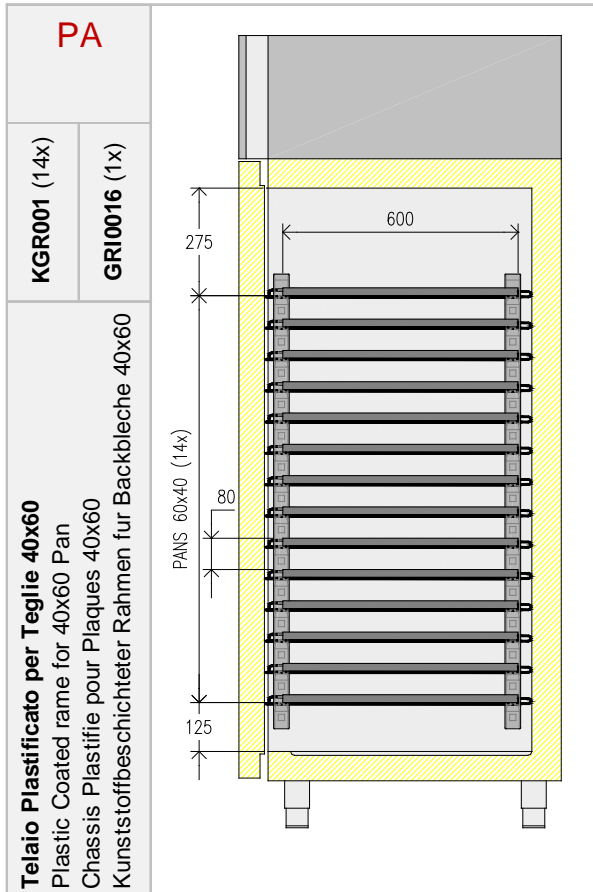
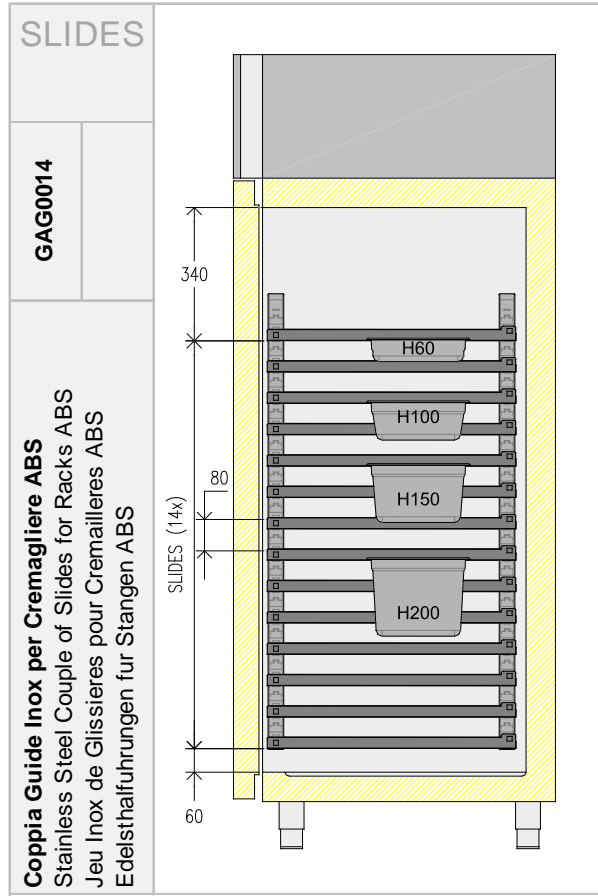
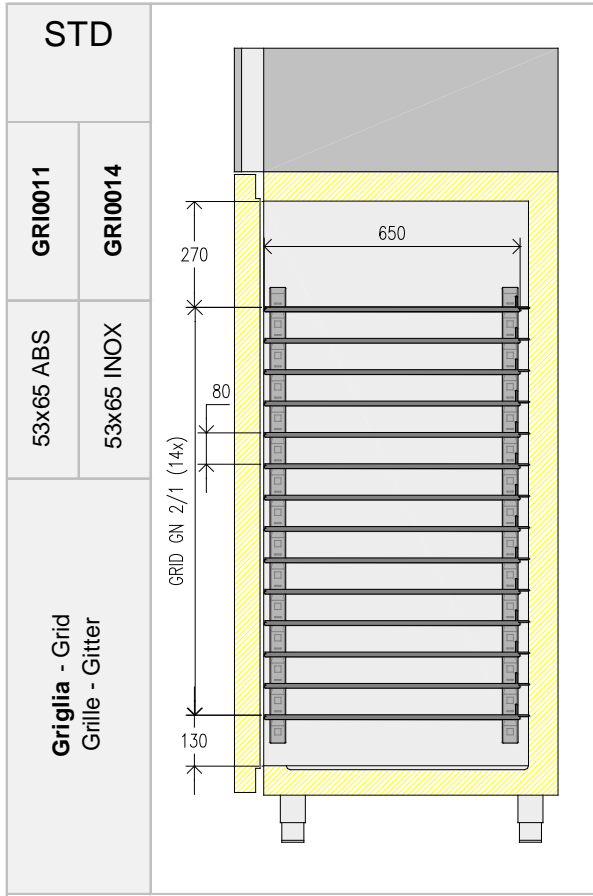

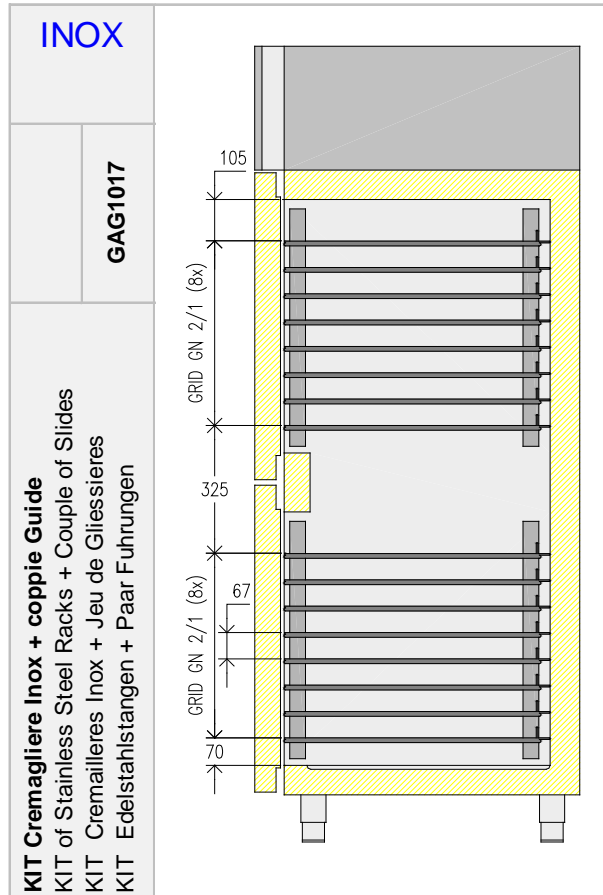
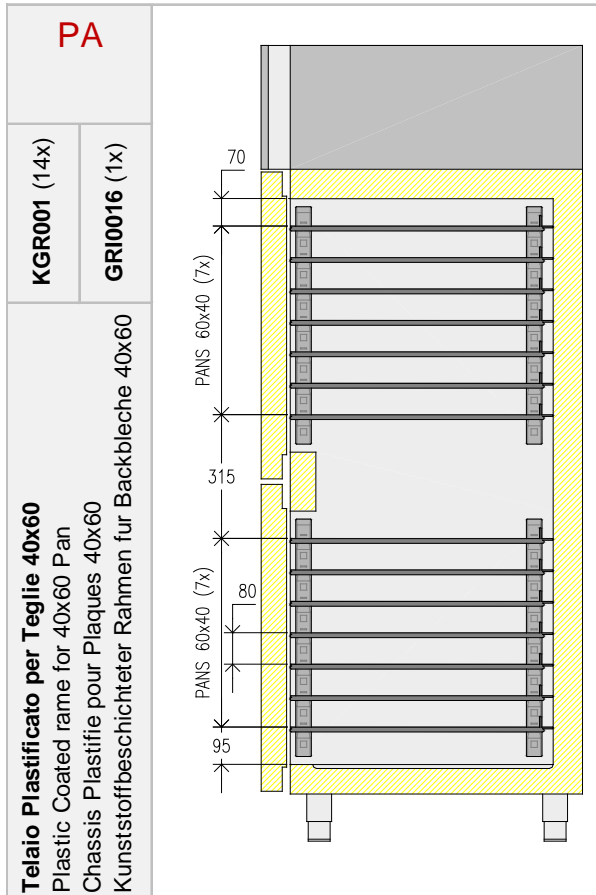
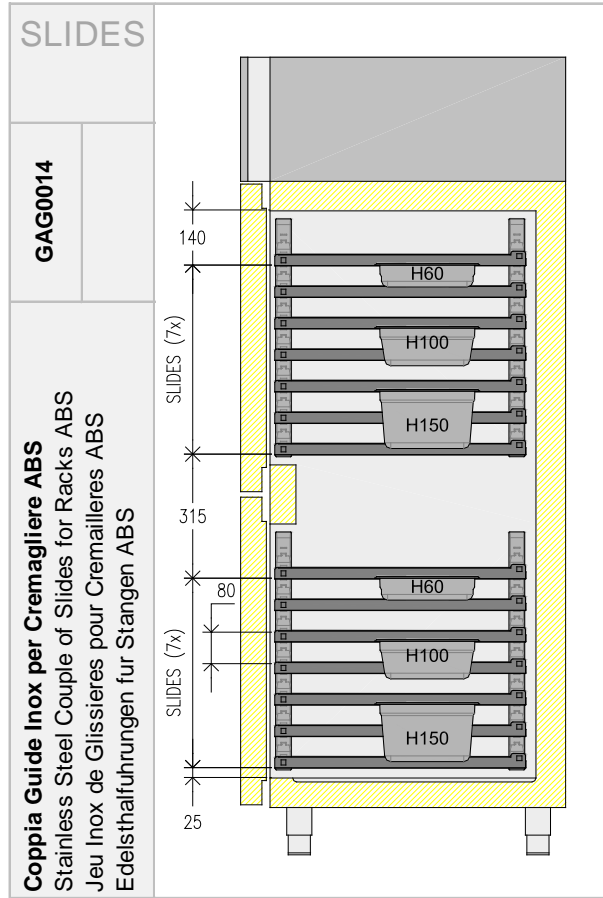
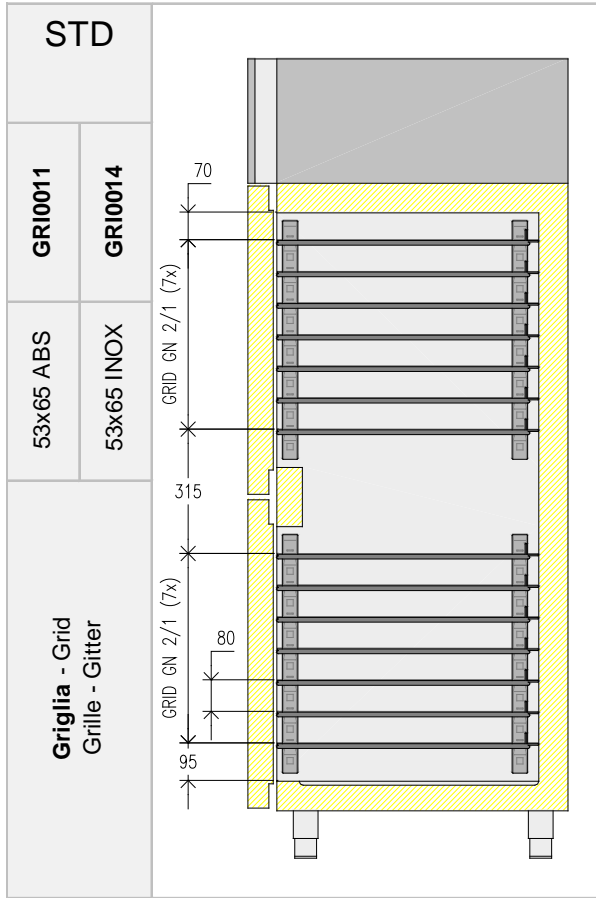

Il costruttore si riserva il diritto di apportare modifiche ai prodotti senza preavviso.
The manufacturer reserves the rights to modify its products without prior notice.
Le constructeur se réserve le droit d'apporter des modifications aux produits sans préavis.
Veränderungen an den Produkten können vom Hersteller ohne Vorankündigung vorgenommen

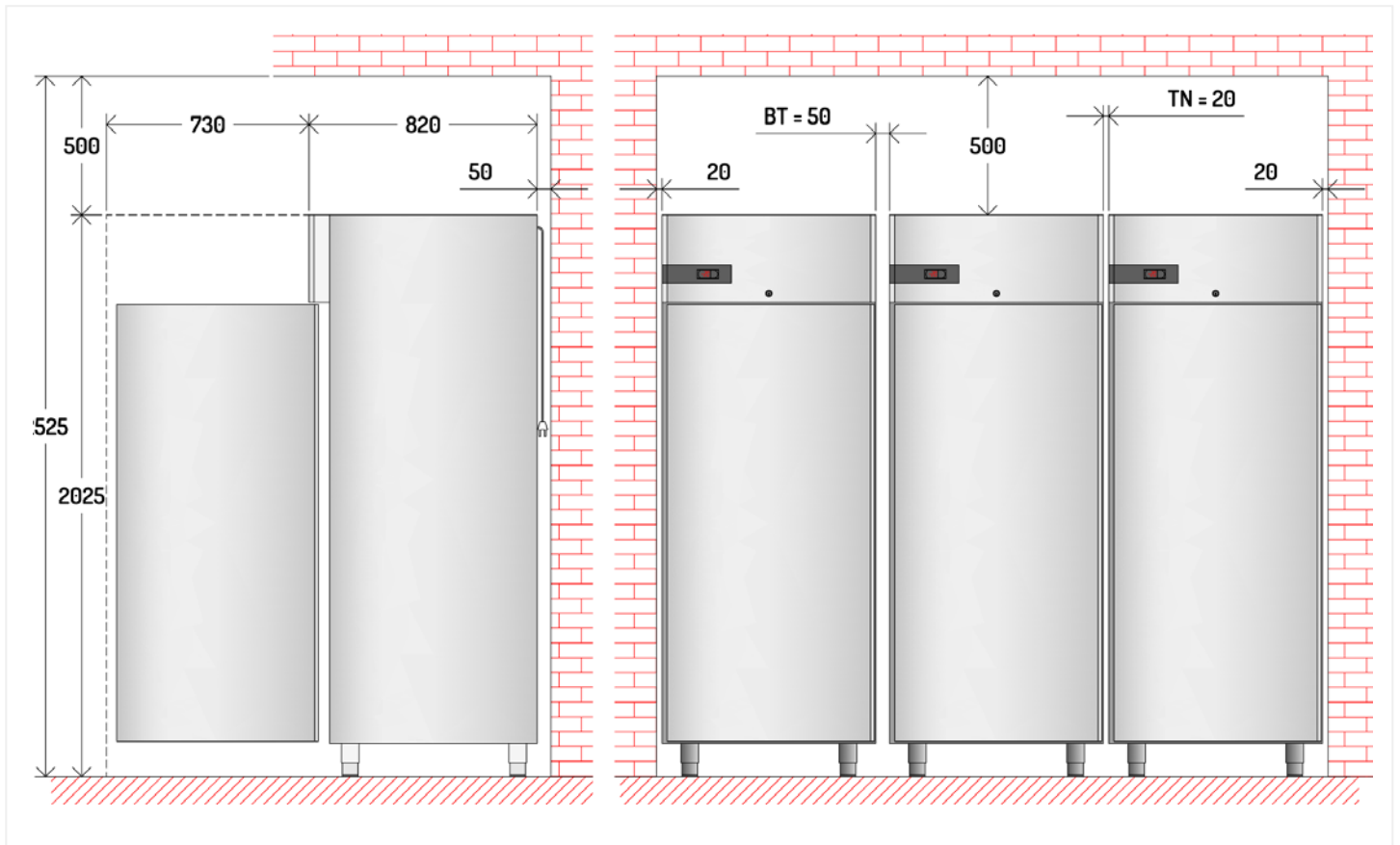

		700 TN	700 BT	
	Ricambio Minimo Aria Minimun Replacement Air	mc/h	170	280
	Calore Emesso Heat Output	watt	210	520
	Versione Remota Remote Version			
	Linea di Aspirazione Suction Line	mm	8	10
	Linea Liquido Liquid Line	mm	6	6
	Potenza Sbrinamento Elettrico Electric Defrost Power	watt	450	900

Modello - Model - Model - Gerätetyp	AN07X6510	AN07Y6510	AN07X6540	AN07X6540
Descrizione - Description - Description - Beschreibung	700 TN		700 TN	
Range	-2°C +8°C		-2°C +8°C	
Funzionamento - Operating Mode - Mode de fonctionnement - Betriebsmodus S = Statico - Static - Statique - Stille Kühlung V = Ventilato - Ventilated - Ventilé - Umluftkühlung	V		V	
Capacità lorda - Gross Capacity - Capacité brute - Bruttovolumen	600		600	
Materiale Esterno - External Material - Matériau Extérieur - Verstoff Außen	3 0 4	4 3 0	3 0 4	4 3 0
Dimensioni esterne - External Dimension - Dimensions externes - ußenabmessungen				
Lunghezza - Width - Largeur - Breite	mm	770	mm	770
Profondità / con porte aperte - Depth / with open doors Profondeur avec portes ouverte - Tiefe / mit geöffneter Tür	mm	820/1520	mm	820/1520
Altezza - Height - Hauteur - Höhe	mm	2025	mm	2025
Materiale Interno - Internal Material - Matériau Intérieur - Verstoff Innen	3 0 4	3 0 4	3 0 4	3 0 4
Dimensioni interne - Internal Dimension - Dimensions internes - Innenabmessungen				
Lunghezza - Width - Largeur - Breite	mm	600	mm	600
Profondità - Depth - Profondeur - Tiefe	mm	682,5	mm	682,5
Altezza - Height - Hauteur - Höhe	mm	1440	mm	1440
Porte - Doors - Portes - Türen	1-DX, Full		2x1/2 ,Full	
Dotazione Standard - Standard Equipment - Equipement standard - Standardausstattung	Griglia plastificata - Plastic-Coated Grid Grille Plastifiée - Kunststoff-Beschichtetes Gitter 530x650		Griglia plastificata - Plastic-Coated Grid Grille Plastifiée - Kunststoff-Beschichtetes Gitter 530x650	
	3		1+1	
Luce interna - Internal light - Eclairage intérieure - Innerbeleuchtung	<input type="checkbox"/>		<input type="checkbox"/>	
Serratura - Lock - Serrure - Schloss	●		●	
Sbrinamento - Defrost - Dégivrages - Abtauen				
Type	Automatic		Automatic	
N° Defrost in 24 hrs.				
Evaporazione acqua sbrinamento - Evaporation of defrost water Evaporation eau de dégivrage - Tauwasserverdunstung	Automaticby Hot Gas		Automaticby Hot Gas	
Compressor	embraco			
Model	VES D9C FULLMOTION		VES D9C FULLMOTION	
Potenza - Power - Puissance - Leistung	HP			
T° Evaporation	°C	-10		-10
Potenza frigorifera - Refrigerant Power - Puissance frigorifique - Kälteleistung	watt	180 - 430		180 - 430
Refrigerante - Refrigerant type - Réfrigérant type - Kältemitteltyp	GWP	R600a / 3		R600a / 3
Quantità di refrigerante - Refrigerant quantity - Quantité de réfrigérant - Kältemittelmenge	gr	100		100
Potenza assorbita - Total Power - Puissance - Leistung	watt	180W - 1,5A (230W - 1,7A)		180W - 1,5A (230W - 1,7A)
Tensione alimentazione - Supply Voltage - Tension d'alimentation - Anschlussspannung	V	230V~ 50Hz		230V~ 50Hz
Noise Level	dbA	49		49
Peso Netto - Net weight - Poids net - Netto Gewicht	kg	130		130
Versione Predisposta - Remote version - Version sans groupe - Modelle ohne Aggregat Sbrinamento elettrico - Electrical defrosting - Dégivrage électrique - Elektrische Abtaung		---		---
Efficienza Energetica - Energy Efficiency - Classe Énergie - Energieeffizienzklasse		A		A
Energia - Energy - Énergie - Energie	kWh / annum	328		328
Volume Netto - Net Volume - Volume Net - Nettoinhalt	l	472		472
Classe Climatica - Climate Class - Classe Climatique - Klima Klasse		5 40°C-40%		5 40°C-40%

● = Dotazione di serie - Standard equipment - Dotation standard - Serien Ausstattung □ = Optional

Modello - Model - Model - Gerätetyp	AN 07X2500	AN 07Y2500	AN 07S2500	AN07X2530	AN07Y2530	AN07S2530
	NEOS GN			0°C +10°C		
Descrizione - Description - Description - Beschreibung		700 TN		700 TN		
Range		0°C +10°C		0°C +10°C		
Funzionamento - Operating Mode - Mode de fonctionnement - Betriebsmodus S = Statico - Static - Statique - Stille Kühlung V = Ventilato - Ventilated - Ventilé - Umluftkühlung		V		V		
Capacità lorda - Gross Capacity - Capacité brute - Bruttovolumen	l	600		600		
Materiale Esterno - External Material - Matériau Extérieur - Werkstoff Außen	3 0 4	4 3 0	P P S	3 0 4	4 3 0	P P S
Dimensioni esterne - External Dimension - Dimensions externes - ußenabmessungen						
Lunghezza - Width - Largeur - Breite	mm	770		770		
Profondità / con porte aperte - Depth / with open doors Profondeur avec portes ouverte - Tiefe / mit geöffneter Tür	mm	820/1520		820/1520		
Altezza - Height - Hauteur - Höhe	mm	2025		2025		
Materiale Interno - Internal Material - Matériau Intérieur - Werkstoff Innen	3 0 4	3 0 4	3 0 4	3 0 4	3 0 4	3 0 4
Dimensioni interne - Internal Dimension - Dimensions internes - Innenabmessungen						
Lunghezza - Width - Largeur - Breite	mm	600		600		
Profondità - Depth - Profondeur - Tiefe	mm	682,5		682,5		
Altezza - Height - Hauteur - Höhe	mm	1440		1440		
Porte - Doors - Portes - Türen		1-DX, Full		2x1/2 ,Full		
Dotazione Standard - Standard Equipment - Equipement standard - Standardausstattung		Griglia plastificata - Plastic-Coated Grid Grille Plastifiée - Kunststoff-Beschichtetes Gitter 530x650		Griglia plastificata - Plastic-Coated Grid Grille Plastifiée - Kunststoff-Beschichtetes Gitter 530x650		
		3		1+1		
Luce interna - Internal light - Eclairage intérieure - Innerbeleuchtung		<input type="checkbox"/>		<input type="checkbox"/>		
Serratura - Lock - Serrure - Schloss		●		●		
Sbrinamento - Defrost - Dégivrages - Abtauen						
Type		Automatic		Automatic		
N° Defrost in 24 hrs.						
Evaporazione acqua sbrinamento - Evaporation of defrost water Evaporation eau de dégivrage - Tauwasserverdunstung		Automatic by Hot Gas		Automatic by Hot Gas		
Compressor	embraco					
Model		EMC3119U		EMC3119U		
Potenza - Power - Puissance - Leistung	HP	1/4		1/4		
T° Evaporation	°C	-10		-10		
Potenza frigorifera - Refrigerant Power - Puissance frigorifique - Kälteleistung	watt	425		425		
Refrigerante - Refrigerant type - Réfrigérant type - Kältemitteltyp	GWP	R290 / 3		R290 / 3		
Quantità di refrigerante - Refrigerant quantity - Quantité de réfrigérant - Kältemittelmenge	gr	80		80		
Potenza assorbita - Total Power - Puissance - Leistung	watt	190W 0,9A		190W 0,9A		
Tensione alimentazione - Supply Voltage - Tension d'alimentation - Anschlussspannung	V	230V~ 50Hz		230V~ 50Hz		
Noise Level	dbA	49		49		
Peso Netto - Net weight - Poids net - Netto Gewicht	kg	130		130		
Versione Predisposta - Remote version - Version sans groupe - Modelle ohne Aggregat Sbrinamento elettrico - Electrical defrosting - Dégivrage électrique - Elektrische Abtauung		---		---		---
Efficienza Energetica - Energy Efficiency - Classe Énergie - Energieeffizienzklasse		B		B		
Energia - Energy - Énergie - Energie	kWh / annum	478		478		
Volume Netto - Net Volume - Volume Net - Nettoinhalt	l	472		472		
Classe Climatica - Climate Class - Classe Climatique - Klima Klasse		5 40°C-40%		5 40°C-40%		

● = Dotazione di serie - Standard equipment - Dotation standard - Serien Ausstattung □ = Optional

Modello - Model - Model - Gerätetyp	AN07X2510	AN07Y2510	AN07S2510	AN07X2540	AN07Y2540	AN07S2540
Descrizione - Description - Description - Beschreibung		700 TN		700 TN		
Range		-2°C +8°C		-2°C +8°C		
Funzionamento - Operating Mode - Mode de fonctionnement - Betriebsmodus S = Statico - Static - Statique - Stille Kühlung V = Ventilato - Ventilated - Ventilé - Umluftkühlung		V		V		
Capacità lorda - Gross Capacity - Capacité brute - Bruttovolumen	l	600		600		
Materiale Esterno - External Material - Matériau Extérieur - Verstoff Außen	3 0 4	4 3 0	P P S	3 0 4	4 3 0	P P S
Dimensioni esterne - External Dimension - Dimensions externes - uße nabmessungen						
Lunghezza - Width - Largeur - Breite	mm	770		770		
Profondità / con porte aperte - Depth / with open doors Profondeur avec portes ouverte - Tiefe / mit geöffneter Tü	mm	820/1520		820/1520		
Altezza - Height - Hauteur - Höhe	mm	2025		2025		
Materiale Interno - Internal Material - Matériau Intérieur - Verstoff Innen	3 0 4	3 0 4	3 0 4	3 0 4	3 0 4	3 0 4
Dimensioni interne - Internal Dimension - Dimensions internes - Innenabmessungen						
Lunghezza - Width - Largeur - Breite	mm	600		600		
Profondità - Depth - Profondeur - Tiefe	mm	682,5		682,5		
Altezza - Height - Hauteur - Höhe	mm	1440		1440		
Porte - Doors - Portes - Türen		1-DX, Full		2x1/2, Full		
Dotazione Standard - Standard Equipment - Equipement standard - Standardausstattung		Griglia plastificata - Plastic-Coated Grid Grille Plastifíee - Kunststoff-Beschichtetes Gitter 530x650		Griglia plastificata - Plastic-Coated Grid Grille Plastifíee - Kunststoff-Beschichtetes Gitter 530x650		
		3		1+1		
Luce interna - Internal light - Eclairage intérieure - Innerbeleuchtung		<input type="checkbox"/>		<input type="checkbox"/>		
Serratura - Lock - Serrure - Schloss		●		●		
Sbrinamento - Defrost - Dégivrages - Abtauen						
Type		Hot Gas		Hot Gas		
N° Defrost in 24 hrs.		3		3		
Evaporazione acqua sbrinamento - Evaporation of defrost water Evaporation eau de dégivrage - Tauwasserverdunstung		Automatic by Hot Gas		Automatic by Hot Gas		
Compressor	embraco					
Model		EMC3119U		EMC3119U		
Potenza - Power - Puissance - Leistung	HP	1/4		1/4		
T° Evaporation	°C	-10		-10		
Potenza frigorifera - Refrigerant Power - Puissance frigorifique - Kälteleistung	watt	425		425		
Refrigerante - Refrigerant type - Réfrigérant type - Kältemitteltyp	GWP	R290 / 3		R290 / 3		
Quantità di refrigerante - Refrigerant quantity - Quantité de réfrigérant - Kältemittelmenge	gr	80		80		
Potenza assorbita - Total Power - Puissance - Leistung	watt	190W 0,9A		190W 0,9A		
Tensione alimentazione - Supply Voltage - Tension d'alimentation - Anschlussspannung	V	230V~ 50Hz		230V~ 50Hz		
Noise Level	dbA	49		49		
Peso Netto - Net weight - Poids net - Netto Gewicht	kg	130		135		
Versione Predisposta - Remote version - Version sans groupe - Modelle ohne Aggregat Sbrinamento elettrico - Electrical defrosting - Dégivrage électrique - Elektrische Abtauerung		<input type="checkbox"/>		<input type="checkbox"/>		
Efficienza Energetica - Energy Efficiency - Classe Énergie - Energieeffizienzklasse		B		B		
Energia - Energy - Énergie - Energie	kWh / annum	478		478		
Volume Netto - Net Volume - Volume Net - Nettoinhalt	l	472		472		
Classe Climatica - Climate Class - Classe Climatique - Klima Klasse		5 40°C-40%		5 40°C-40%		

● = Dotazione di serie - Standard equipment - Dotation standard - Serien Ausstattung = Optional

Modello - Model - Model - Gerätetyp	AN07X2520	AN07Y2520	AN07S2520	AN07X2550	AN07Y2550	AN07S2550
	NEOS GN			-20°C -10°C		
Descrizione - Description - Description - Beschreibung		700 BT		700 BT		
Range		-20°C -10°C		-20°C -10°C		
Funzionamento - Operating Mode - Mode de fonctionnement - Betriebsmodus S = Statico - Static - Statique - Stille Kühlung V = Ventilato - Ventilated - Ventilé - Umluftkühlung		V		V		
Capacità lorda - Gross Capacity - Capacité brute - Bruttovolumen	l	600		600		
Materiale Esterno - External Material - Matériau Extérieur - Verstoff Außen	3 0 4	4 3 0	PPS	3 0 4	4 3 0	PPS
Dimensioni esterne - External Dimension - Dimensions externes - uße nabmessungen						
Lunghezza - Width - Largeur - Breite	mm	770		770		
Profondità / con porte aperte - Depth / with open doors Profondeur avec portes ouverte - Tiefe / mit geöffneter Tü	mm	820/1520		820/1520		
Altezza - Height - Hauteur - Höhe	mm	2025		2025		
Materiale Interno - Internal Material - Matériau Intérieur - Verstoff Innen	3 0 4	3 0 4	3 0 4	3 0 4	3 0 4	3 0 4
Dimensioni interne - Internal Dimension - Dimensions internes - Innenabmessungen						
Lunghezza - Width - Largeur - Breite	mm	600		600		
Profondità - Depth - Profondeur - Tiefe	mm	682,5		682,5		
Altezza - Height - Hauteur - Höhe	mm	1440		1440		
Porte - Doors - Portes - Türen		1-DX, Full		2x1/2, Full		
Dotazione Standard - Standard Equipment - Equipement standard - Standardausstattung		Griglia plastificata - Plastic-Coated Grid Grille Plastifiée - Kunststoff-Beschichtetes Gitter 530x650		Griglia plastificata - Plastic-Coated Grid Grille Plastifiée - Kunststoff-Beschichtetes Gitter 530x650		
		3		1+1		
Luce interna - Internal light - Eclairage intérieure - Innerbeleuchtung		<input type="checkbox"/>		<input type="checkbox"/>		
Serratura - Lock - Serrure - Schloss		<input checked="" type="checkbox"/>		<input checked="" type="checkbox"/>		
Sbrinamento - Defrost - Dégivrage - Abtauen						
Type		Hot Gas		Hot Gas		
N° Defrost in 24 hrs.		3		3		
Evaporazione acqua sbrinamento - Evaporation of defrost water Evaporation eau de dégivrage - Tauwasserverdunstung		Automatic by Hot Gas		Automatic by Hot Gas		
Compressor						
Model		NEU2168U		NEU2168U		
Potenza - Power - Puissance - Leistung	HP	3/4		3/4		
T° Evaporation	°C	-30		-30		
Potenza frigorifera - Refrigerant Power - Puissance frigorifique - Kälteleistung	watt	600		600		
Refrigerante - Refrigerant type - Réfrigérant type - Kältemitteltyp	GWP	R290 / 3		R290 / 3		
Quantità di refrigerante - Refrigerant quantity - Quantité de réfrigérant - Kältemittelmenge	gr	130		130		
Potenza assorbita - Total Power - Puissance - Leistung	watt	580W 2,9A / 840W 4A		580W 2,9A / 840W 4A		
Tensione alimentazione - Supply Voltage - Tension d'alimentation - Anschlussspannung	V	230V~ 50Hz		230V~ 50Hz		
Noise Level	dbA	58		58		
Peso Netto - Net weight - Poids net - Netto Gewicht	kg	140		145		
Versione Predisposta - Remote version - Version sans groupe - Modelle ohne Aggregat Sbrinamento elettrico - Electrical defrosting - Dégivrage électrique - Elektrische Abtauerung		<input type="checkbox"/>		<input type="checkbox"/>		
Efficienza Energetica - Energy Efficiency - Classe Énergie - Energieeffizienzklasse		C		C		
Energia - Energy - Énergie - Energie	kWh / annum	1892		1892		
Volume Netto - Net Volume - Volume Net - Nettoinhalt	l	472		472		
Classe Climatica - Climate Class - Classe Climatique - Klima Klasse		5 40°C-40%		5 40°C-40%		

● = Dotazione di serie - Standard equipment - Dotation standard - Serien Ausstattung = Optional